

6 POSITION REVERSIBLE CAM STAY ON BOTH SIDES. TABLE CAN BE MOVED BACK TO FLAT WITHOUT GOING ALL THE WAY UP.

1/2" BLACK UHMW PLASTIC LIP 1.5" ABOVE TOP OR SPECIFY

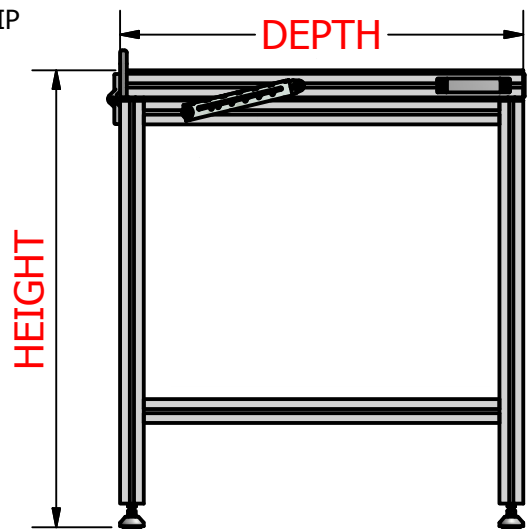

E-MAIL SALES@MINITECFRAMING.COM WITH YOUR WIDTH, DEPTH & HEIGHT FOR A FREE QUOTE TODAY

PROJECT SP082316-1		MiniTec THE ART OF SIMPLICITY	WWW.MINITECFRAMING.COM	
DRAWN BY ANDY MOLES			VICTOR, NY	
DATE 8/26/2016		PH # 585 924-4690		DIRECT 585 398-1240 EXT 104
DRAWN FOR MINITEC'S CUSTOMER		DWG NO SP082316-1		REV
TOLERANCES UNLESS OTHERWISE NOTED X +/- .125" .XX +/- .015" .XXX +/- .010"		MATERIAL		SHEET 1 OF 3
		FINISH		



22.1078 RUBBER BUMPER ENTIRE PERIMETER

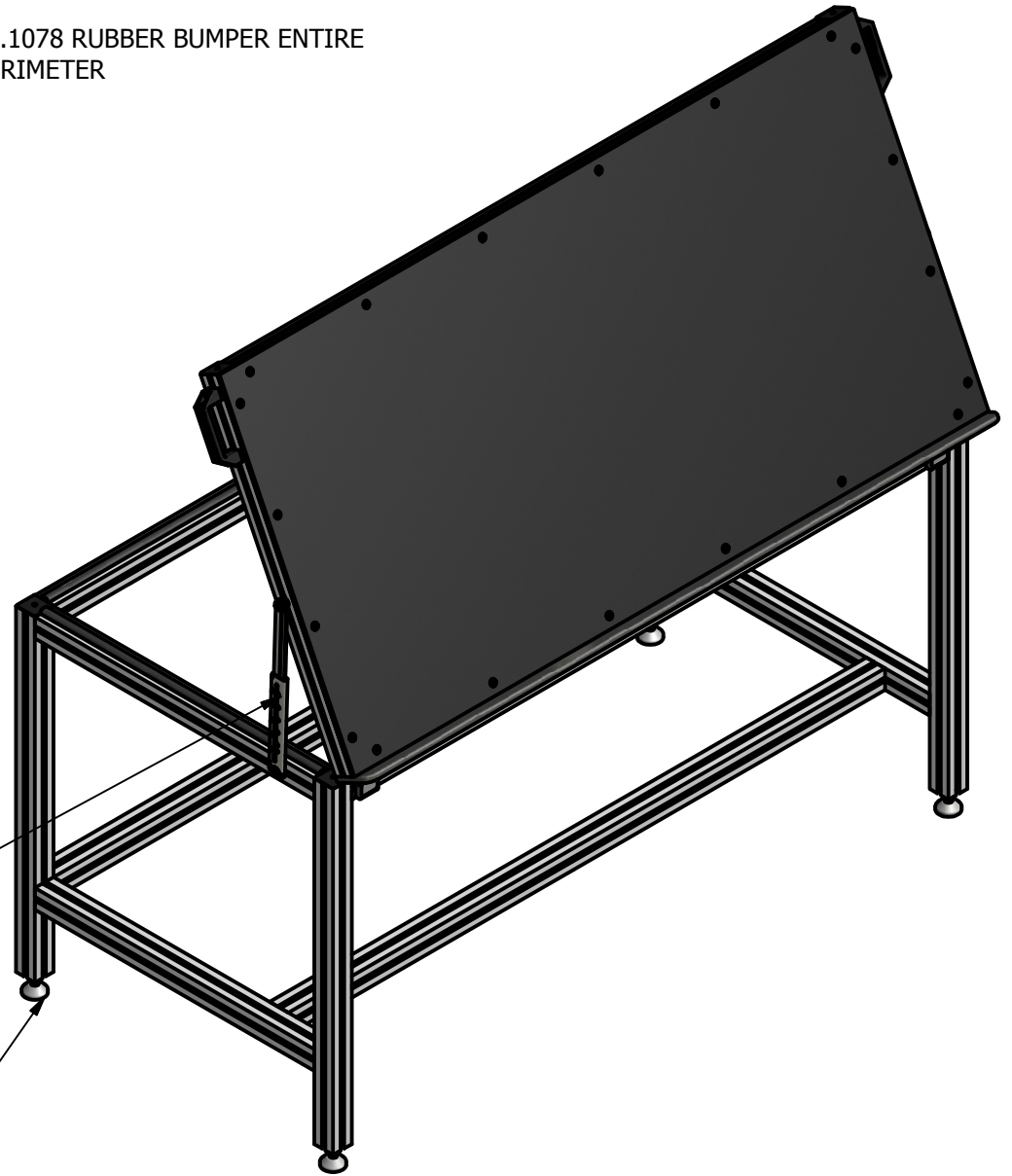



CAM STAY MOUNTING POSITION CAN BE MOVED TO ADJUST LOWEST & HIGHEST POSITION OF TOP AS WELL AS TOPS INCREMENTAL MOVEMENT IN EACH OF THE 6 POSITIONS

21.1871 M8 LEVELING PADS OR SPECIFY

PROJECT SP082316-1		 <small>WWW.MINITECFRAMING.COM VICTOR, NY PH # 585 924-4690 DIRECT 585 398-1240 EXT 104 FX # 585 924-4821 amoles@minitecframing.com</small>	REV
DRAWN BY ANDY MOLES			DWG NO
DATE 8/26/2016			SP082316-1
DRAWN FOR MINITEC'S CUSTOMER	TITLE TILT TABLE WITH FLAT TOP & LIP	MATERIAL	
<small>TOLERANCES UNLESS OTHERWISE NOTED .X +/- .12" .XX +/- .015" .XXX +/- .010"</small>		FINISH	SHEET 2 OF 3

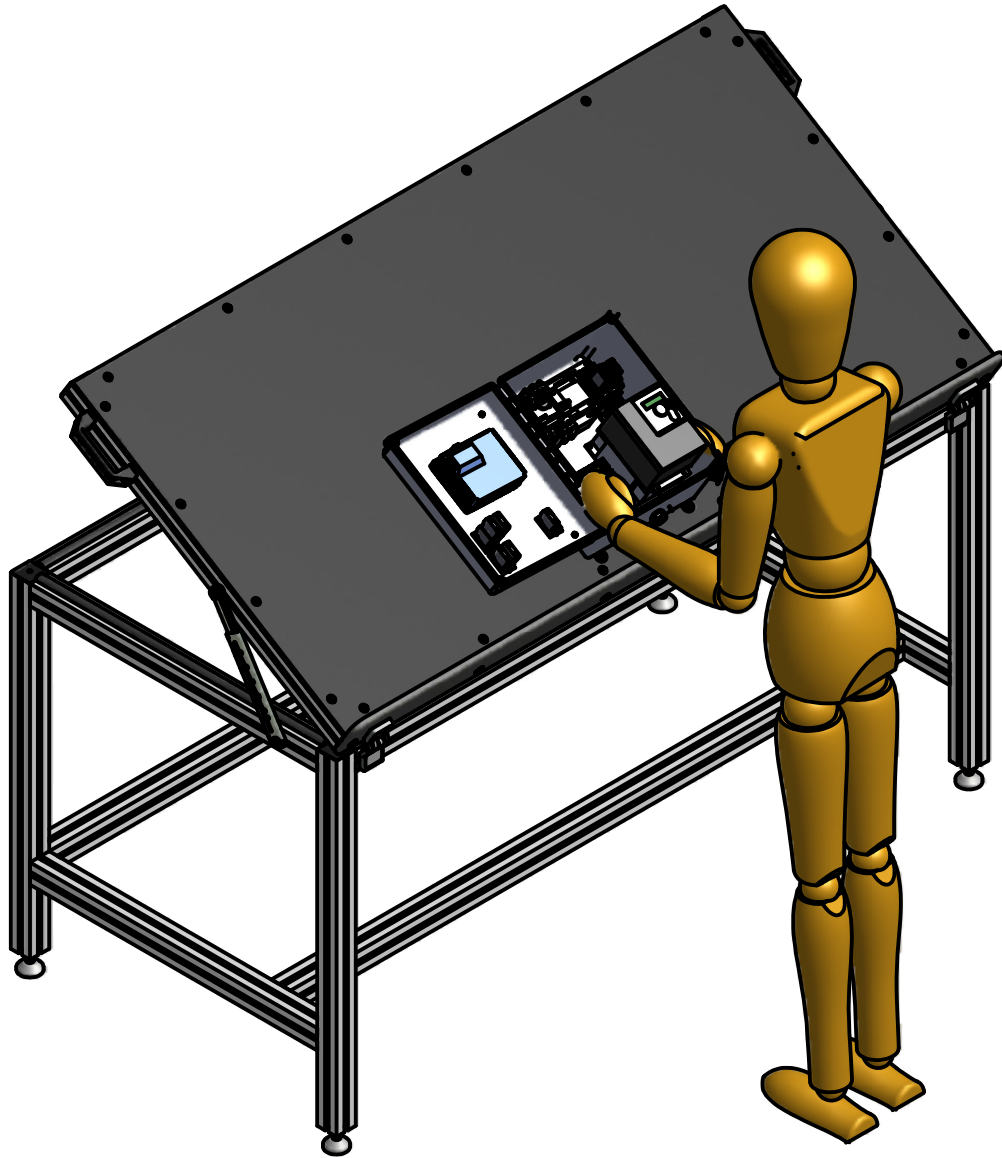
ERGONOMIC ASSEMBLY. REDUCE BACK STRAIN BY TILTING TABLE TOWARD ASSEMBLER



PROJECT SP082316-1			WWW.MINITECFRAMING.COM VICTOR, NY PH # 585 924-4690 DIRECT 585 398-1240 EXT 104 FX # 585 924-4821 amoles@minitecframing.com		
DRAWN BY ANDY MOLES					
DATE 8/26/2016					
DRAWN FOR MINITEC'S CUSTOMER		TITLE TILT TABLE WITH FLAT TOP & LIP		DWG NO SP082316-1	REV
TOLERANCES UNLESS OTHERWISE NOTED .X +/- .1/32" .XX +/- .015" .XXX +/- .010"		MATERIAL		FINISH	
				SHEET 3 OF 3	